

UR-2Q
UH-2
UT-2

Dante Quad-channel true diversity
UHF wireless microphone

Simple Operation Manual

Before using the product, please read the simple operation manual and keep it in good condition.



Packing list

UR-2Q

- ◆ Receiver * 1
- ◆ Transmitter * 4 (handheld, bodypack is optional)
- ◆ BNC antenna * 2
- ◆ The power cable * 1
- ◆ 1.5V AA batteries * 8
- ◆ 1 meter audio cable * 1
- ◆ 1 U rack mount kit (screw) * 1 set
- ◆ Simple and easy operating instructions * 1

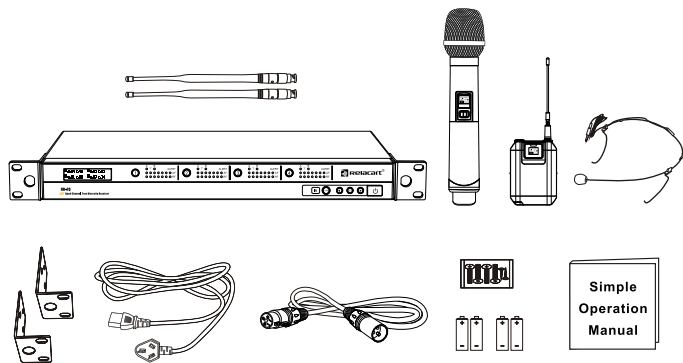

Receiver front panel function introduction

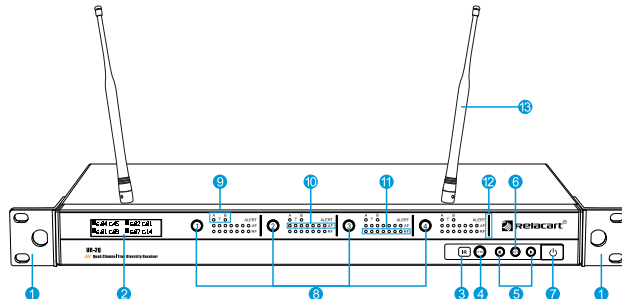

- ① Rack mount kit: fixed installation;
- ② LCD display: System settings and parameters;
- ③ Infrared (IR) window: send infrared signal to the transmitter, in order to realize the synchronization;
- ④ SYNC button: Press the "SYNC" button, synchronization of transmitters via IR interface from receiver;
- ⑤ "◀", "▶" allow control button: press the allow button to edit the menu parameter values;
- ⑥ "SET" button: press to enter or select the menu;
- ⑦ Power switch: turn on the receiver of power supply, long press to turn off the receiver;
- ⑧ Channel button: this 1/2/3/4 buttons, press to enter the current independent channel setting parameters or exit menu;
- ⑨ AB antenna display;
- ⑩ AF signal display;

- ⑪ RF signal display;
- ⑫ ALERT alarm;
- ⑬ 1/2 wavelength BNC antenna: used to receive radio transmitter for transmission.

Receiver rear panel function introduction

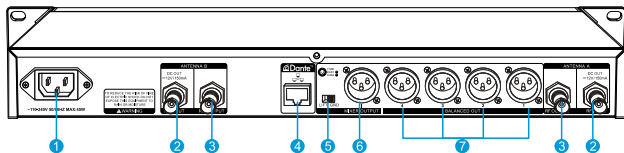

- ① The ac power input: IEC connector, 110-240V AC;
- ② RF antenna input connector: BNC connectors, apply to receive radio signals, and to support the DC 12V/150 mA power output;
- ③ RF antenna output connector: suitable for more than one receiver use, provide RF signal to other receiver;
- ④ Ethernet port/ Dante network: Connect to Ethernet to transmit Dante digital audio and control signals for audio distribution, monitoring and recording - Reference "Dante network" theme;
- ⑤ LIFT/GND switch: control XLR pin 1 whether is contact GND;
- ⑥ Main audio balance OUTPUT socket (MIXER OUTPUT) : XLR card socket, all channel audio can be output here;
- ⑦ Single channel audio balance OUTPUT socket (BALANCED OUT) : Output each channel of audio separately.

Handheld transmitter function instruction

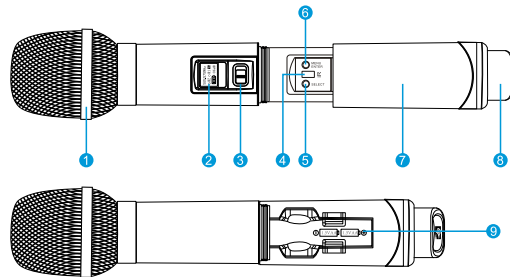

- ① The microphone cartridge: used to pick up the audio to the transmitter modulation;
- ② OLED display: display frequency, group, channels, battery life, etc;
- ③ Power supply switches, turn the power on or off;
- ④ Infrared (IR) window: synchronization of transmitters via IR interface from receiver;
- ⑤ "SELECT" button: press the button to edit the menu parameter values;
- ⑥ Menu setting button: press to enter or confirm the setting;
- ⑦ Battery cover: When installing, replacing or setting the infrared frequency, the battery cover must be opened;
- ⑧ Handheld transmitter tail cover: integrated antenna transmit output port;
- ⑨ Battery holder: Install 2 AA batteries.

Bodypack transmitter function instruction

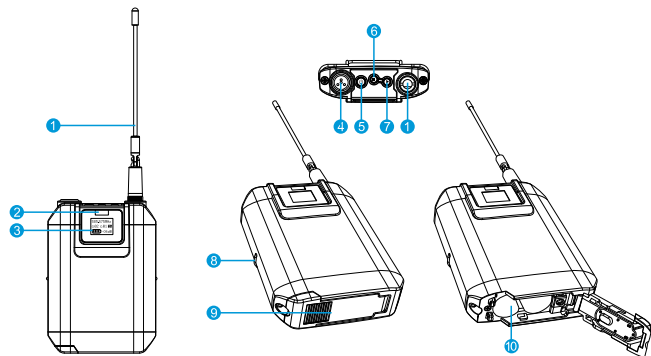

- 1 ϕ 3.5mm with nut lock antenna: For transmitting a bodypack radio carrier;
- 2 Infrared (IR) window: Aligning the infrared port of the receiver allows the transmitter to synchronize with the receiver frequency during infrared synchronization;
- 3 OLED display: display frequency, group, channel, battery life, etc;
- 4 MINI 4-pin audio input socket;
- 5 Light touch power switch: turn the power on or off;
- 6 Press to enter or confirm the setting;
- 7 Press the button to edit the menu parameter values;
- 8 Bodypack holder: used to fix the bodypack on the clothes;
- 9 Battery cover: When installing, replacing or setting the infrared frequency, the battery cover must be opened;
- 10 Battery holder: Install 2 AA batteries.

Receiver device installation

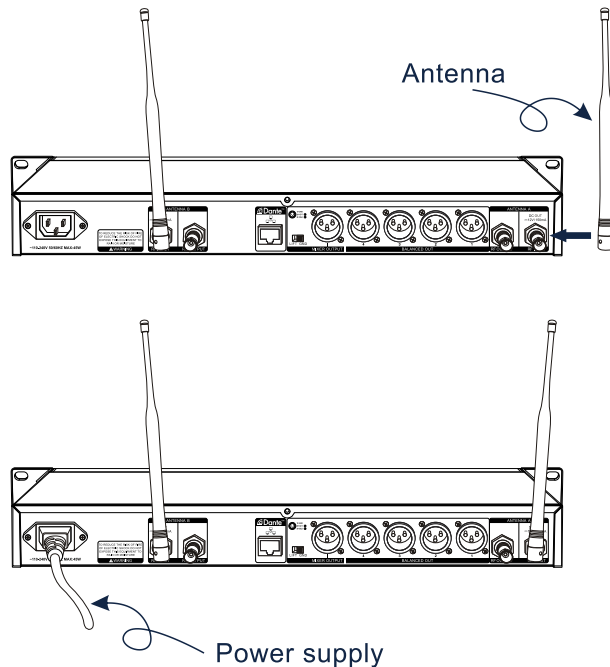

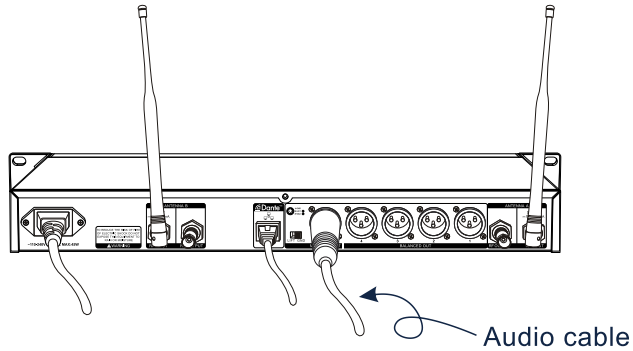
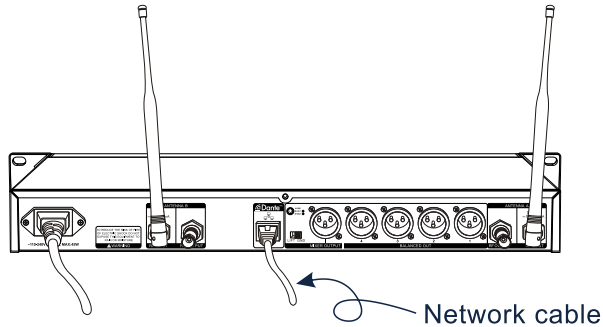

Multiple receivers connected to the RF distribution port

The RF distribution port can transmit RF signals from one receiver to the next, allowing up to 5 receivers to share a pair of antennas. Connect the ports of each receiver using the supplied RF distribution cable as shown below.

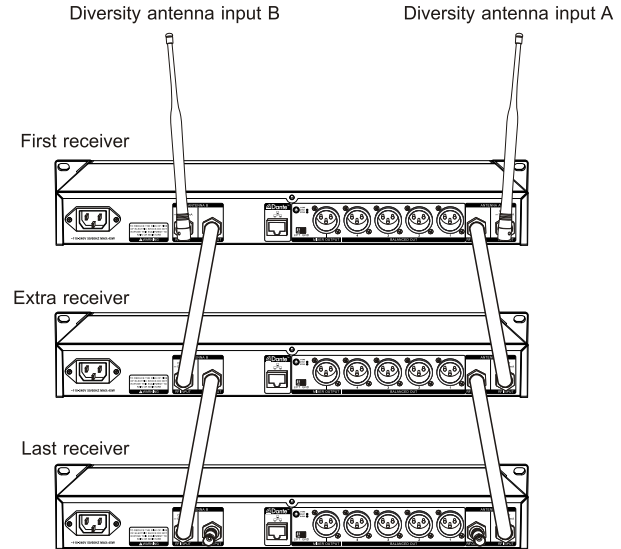

(Note: all receivers must be operating in the same frequency band.)

Handheld microphone battery installation

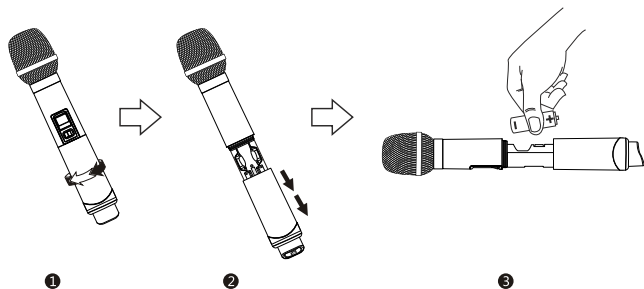

Bodypack transmitter battery installation

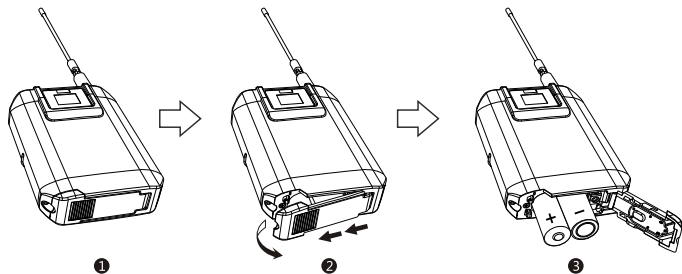

Simple operation step

1. After connecting the antenna and the power cable, press the power button to turn on the receiver. When the display is lit, the power is turned on successfully.

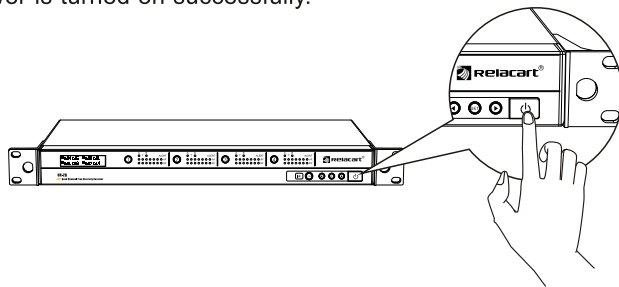

2. Press and hold the receiver "SET" button to enter the menu setting;

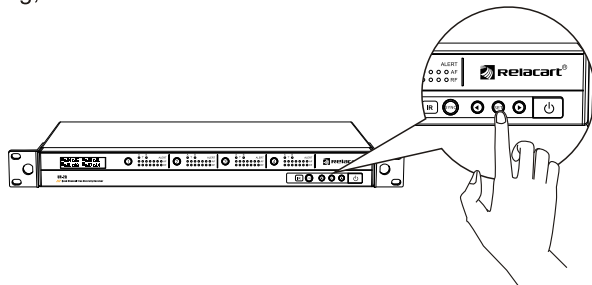

Simple operation step

3. Press the corresponding channel button, then short press "SET" to enter the channel mode setting; (as shown below)

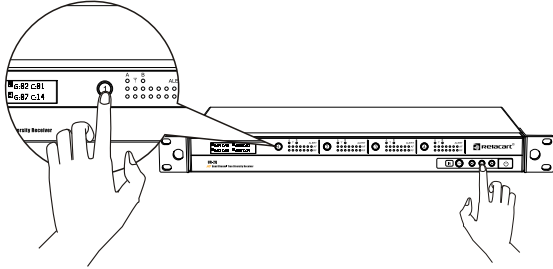

4. Automatic frequency scan: After selecting the channel button, press the "SET" button to enter the automatic scan function (AFS), and then select "Auto-scan group" / "Auto-scan channel" will appear the automatic scan interface. (As shown below)

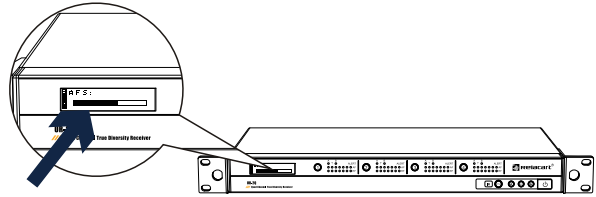
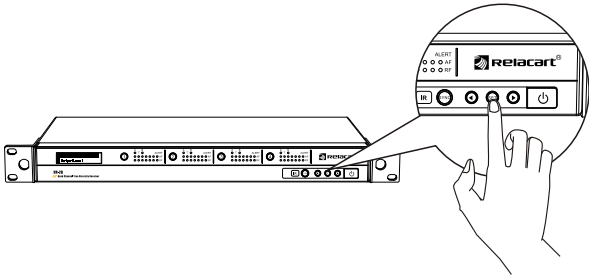

The scan channel automatically calculates a free frequency, and the "RF" light on the receiver indicator does not illuminate; if not, repeat this action until the clean channel is scanned.

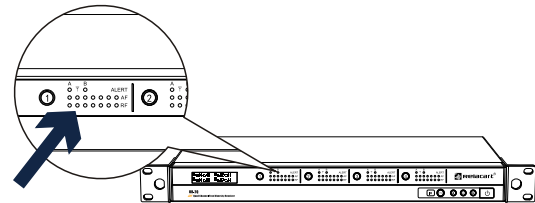

5. The transmitter's infrared window facing to the receiver IR port. Press the "Sync" button.

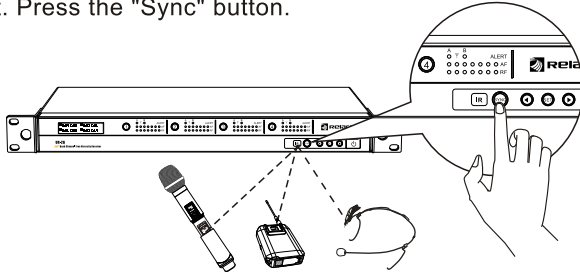

The frequency of the transmitter and the receiver are synchronized. When talking with the microphone, the "AF" signal in the display jumps to indicate that there is an audio output.

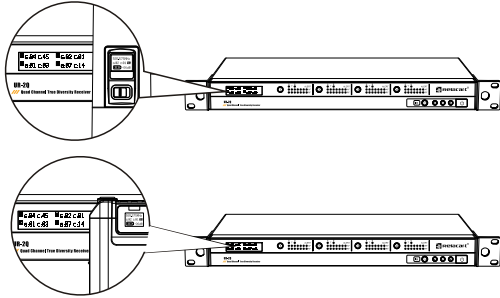

Channel display (receiver and transmitter display the same frequency)

Receiver and transmitter features introduced

UR-2Q Receiver Menu

Desktop: Desktop mode display(group/channel, frequency,name)

Brightness: Brightness(high,medium,low)

Receiver Lock: Receiver Lock(unlock,lock)

Tools: Tools(branch menu) — Pilot Tone: Pilot Tone(OFF,ON)
 — Transmitter lock: Transmitter Lock(unlock,lock)
 — Device ID: Device ID
 — Version: Version
 — System Reset: System Reset(YES,NO)
 — Exit: Exit branch menu setting

Language: Language(Chinese,English)

Exit: Exit menu setting

UR-2Q Channel menu

Squelch: adjust receiver sensitivity(05dB-35dB)

Frequency List: frequency setting(Channel,Frequency)

AFS: auto frequency scan (Channel,Group)

Output Level: (analog output,digital output)

Magic EQ: Intelligent management of sound

Edit Name: Edit Name

Exit: Exit menu setting

UR-2Q handheld microphone menu, bodypack transmitter men

Input Gain: (-12dB, -06dB, 00dB, +3dB)

RF power: (high,low)

TX Lock: Transmitter Lock(unlock,lock)

Tools: Tools(branch menu) —

- Brightness: Brightness(high,medium,low)
- Mute mode: Mute(YES, NO) (bodypack)
- Version: Version
- TX Reset: Reset(YES, NO)
- Exit: Exit branch menu setting

Exit: Exit menu setting

Safety operation and Notice

1. Please read instructions for safety operation carefully before installation and operation. Please save your safety operation guide for future reference.
2. Do not scratch, bend, twist, stretch or heat the power cord as this may cause damage to the power cord, resulting in a fire or electric shock.
3. Do not open the device shell, otherwise it may cause electric shock. If you need to repair, maintain or repair, please contact your local agent.
4. Do not touch the power plug with wet hands as this may cause a fire or electric shock.
5. Do not attempt to modify this device. Failure to do so may result in personal injury or product malfunction.
6. Do not use this equipment near water.
7. If the power cord is damaged (such as a broken wire or bare core), obtain replacement parts from your dealer. Continued use of the equipment with a damaged power cord may result in fire or electric shock.
8. To move the device he power, unplug the power cord, and unplug all connecting cables as this may damage the cable, resulting in a fire or electric shock.
9. Before cleaning the device, unplug the power cord and unplug all connecting cables. Please clean it with a dry soft cloth.
10. If the device is not in use for a long time, turn off the power, it is best to unplug the socket.
11. With the power plug and appliance coupler as the disconnecting device, it should be kept easy to operate.
12. For the safe use of the equipment and adequate ventilation, the minimum clearance around the equipment should be maintained at a distance of 5cm or more.
13. DO NOT cover the Ventilation holes, such as: newspaper / fabric / curtains and other items.
14. Equipment should not be placed on a bare flame source, such as: lit candles.
15. Battery should not be exposed to sunshine, roasted or other high temperature overheating environment.
16. Do not throw the waste battery, please put in the designated bins.
17. Water protection rating: IPX0
18. The device can be used normally in tropical / temperate climates.
19. This product is only suitable for safe use at the altitude of 2000m and below.
20. This symbol "⚡" indicates that dangerous voltage constituting a risk of electric shock is present within this unit.
21. All Relacart products will be afforded one year free maintenance except for man-made damage, such as:
 - the device is damaged by man-made factors.
 - the device is damaged by improper operation.
 - some components are damaged or loss after the self-disassembly.